



ELECTRIC SUPRBOARDS AND EFOILS

EU/GLOBAL

# USER MANUAL

---

## AWAKE VINGA SERIES



UM-VG\_2.1/EU-GLOBAL

# Foreword

Please read this manual carefully before you start using the Awake VINGA. Ignoring the instructions in this operating manual can cause damage and significant personal injury. Awake accepts no liability for any damage caused by actions that contradict this operating manual. The Awake VINGA is designed to be operated by a person (rider or operator) sitting, standing or kneeling.

Only allow adults who are in good physical condition and mental health, and not under the influence of any substance (alcohol and/or other drugs), which may impair vision, dexterity and/or judgement, and have been fully instructed on and have understood how to operate or use the electric watercraft.

Never attempt to repair or open the Awake VINGA by yourself. Any procedures not covered or described in this manual are only to be carried out by an authorized technician at your nearest dealership or by Awake.

# How to Awake

Get started and find out more about how you can optimize your Awake experience through our digital platforms.

Scan the QR-codes with your smart device to access setup guides, digital user guides, technical specifications, tutorials and more.

## Manually access our digital platforms:

- [support.awakeboards.com](https://support.awakeboards.com)
- [www.awakeboards.com](https://www.awakeboards.com)
- [www.youtube.com/@AwakeBoards](https://www.youtube.com/@AwakeBoards)

## Video tutorials



## Support platform



# General and important symbols and labels

In the manual you find these symbols and signs. Information of particular importance is distinguished in the following ways:



This is the safety alert symbol. It is used to alert you to potential personal injury hazards. Obey all safety messages that follow this symbol to avoid possible injury or death.



A WARNING indicates a hazardous situation which, if not avoided, could result in death or serious injury.

## **NOTICE**

A NOTICE indicates special precautions that must be taken to avoid damage to the electric watercraft or other property, or to inform about (but are not limited to) legal parameters, guarantee and warranty information.

# To the owner of The Awake VINGA

Congratulations on becoming the proud owner of an Awake VINGA eFoil! The Awake VINGA is an innovative water sports product that allows you to experience the thrill of surfing independently of waves or boats.

The Awake VINGA is emission-free due to the electric jet propulsion system and is proudly designed and developed in Sweden.

Familiarize yourself with all the information provided in this manual as there is an inherent risk involved in operating any electric hydrofoil and any motor-powered electric watercraft. This manual should be considered a permanent part of this electric watercraft and should remain with it even if the electric watercraft is sold or changes ownership.

Awake constantly strives towards the improvement of our products and technology. As a result, Awake reserves the right to change or modify any information provided in this manual, including specification, at any time without prior notice. The specifications and functions described in this user manual may differ from those delivered at the time you received your product. Be sure to, on a frequent basis, visit [www.awakeboards.com](http://www.awakeboards.com) (Awake's website) to read and download the latest version about specifications and functions.

This User Manual cannot anticipate every circumstance involved in owning or operating the Awake VINGA. Awake cannot anticipate all types of activities or negligent performance that may result in injury, death or damage. The operator accepts full responsibility for the use of the Awake VINGA in a safe and sensible manner. Pay special attention to surroundings at all times to avoid accidents.

Ride Awake strongly encourages owners and operators to regularly review the information provided by the relevant local authority, i.e. laws and regulations pertaining to the use of personal electric watercraft, such as the local coast guard or the relevant authority regulating the laws pertaining to the use of personal electric watercraft with particular attention to information provided for personal electric watercraft.

## Definitions and terminology

### ***VINGA eFoil:***

Electric hydrofoil that elevates the board with the help of wings. Allows the rider to “fly” above the surface.

### ***Flex BP:***

BP is the abbreviation of Awake's battery or battery pack – 'Battery Pack'.

### ***SR:***

SR is short for 'Standard Range', and is used to define Awake's standard BP; the 'SRBP', as well as a board that has the SR Flex BP, for example; 'VINGA SR'.

### ***XR:***

XR is short for 'Extended Range', and is used to define Awake's larger BP; the 'XRBP', as well as a board that has been upgraded with an XR Flex BP, for example; 'VINGA XR'.

### ***Flex HC:***

HC is the abbreviation of 'Hand Controller'.

### ***PKL / CPK:***

PKL is the abbreviation of the magnetic power key leash that is used to activate the board – 'Power Key Leash'. The PKL must be attached to your person at all times.

CPK – 'Competition Power Key' – is designed to be attached to the board leaving space for the riders front foot.

### ***CM:***

The CM is the connector module where the male connector is found (the pins that is sticking out at the bottom of the BP compartment in the board.

### ***Rotary lock:***

The rotary lock is the big handle on the "rear" of the Flex BP (the opposite side to the LED screen. This is used to connect the BP firmly to the board when riding and to the charger when charging.

### ***Nose/tail foot strap:***

The nose foot strap is the foot strap that is positioned towards the front (nose) of the board. Naturally, the tail foot strap is the foot strap positioned towards the board's back (tail).

### ***SOC:***

SOC is short for "State Of Charge" and is used to define the level of charge of the Flex BP or Flex HC in percent. Where 100% is fully charged and 0% represents empty.

# Table of Contents

How to Awake	3
General and important symbols and labels	4
To the owner of The Awake RÄVIK	5
Definitions and terminology	6
1 Important labels	8
2 Safety Information	14
3 Operation	24
4 Transport and Storage	32
5 Maintenance	35
6 Troubleshooting and diagnostics	36
7 Warranty & Guarantee	38
8 Technical Specifications	39
9 Contact Us	44

# 1 Important labels

## 1.1 Warning label specification

### 1.1.1 Awake VINGA eFoil

**FAILURE TO COMPLY CAN CAUSE SERIOUS INJURY OR DEATH!**

**Read all labels carefully before using any Awake equipment. Each module is marked with a yellow warning and black serial number label**

**Always use Awake vehicles responsibly!**

This is an extreme sports product and should be used carefully; using it over your skill level may result in injuries or death.

Always inspect the product prior to use to ensure that it is undamaged and suitable for use. Never use a product that you suspect to be damaged.

Users under 16 years of age must use the eFoil in ECO mode only.

Only able swimmers should use the product. The user should remain close enough to shore to swim back should the product cease to function.

Always wear a life vest in accordance with European health, safety, and environmental protection standards.

Only use the board with a full-face helmet protecting both the head and the face.

Failure to do so will increase the risk of injury or death. A helmet should be worn at all times as to mitigate liability in case of injury.

You should know that a helmet could help protect you in certain accidents and that it could injure you or others. A helmet is designed to provide some head protection. Although helmets can not protect against all foreseeable impacts, a helmet might reduce your injuries if falling on the board, crashing into an object or in a collision with another electric watercraft. A helmet may have potential safety hazards as well. Falling into the water could risk the chance of the helmet catching water, commonly known as "bucketing", and the resulting strain on your neck could cause choking and severe and permanent neck injuries or death.

If falling off the board, always fall towards the rear or sides of it. Falling on the board or in front of the board may result in injury or death. Always protect your face, head and neck with your hands and arms when falling off the board.

Always use the electric watercraft with the PKL securely and safely fastened to a life

jacket, clothing, or your body.

Always use the eFoil with the Flex HC lanyard securely fastened on the wrist of the hand that will hold the Flex HC.

Always keep the safety leash attached to your life vest when riding the eFoil.

Always maintain full awareness of people, crafts, objects, and shoreline in the area where you are riding the eFoil.

Always maintain maximum visibility while riding the eFoil, and avoid situations where you may not been seen by others on or in the water.

Always respect any wildlife you may encounter and the nature you explore while riding the eFoil.

When learning to ride the eFoil or riding the first time, do not use any speed setting on the app higher than ECO mode. Use riding mode ECO the first time you ride the board and until you can operate the board in a controlled and safe way.

Always follow local regulations where you intend to use this type of product.

Never ride beyond your skill level in areas where there are obstacles, traffic, wildlife or other hazards.

Make sure the operator has practiced accessing/getting up on the board close to shore before riding the board. A person who has made many unsuccessful attempts to get back on the eFoil may become fatigued and suffer from exposure, increasing risk of injury and drowning.

**To avoid collision:**

- Scan constantly for people, objects, animals and other electric watercraft, and be aware of conditions that can limit your visibility or block your vision of others.
- Operate defensively at safe speeds and keep a safe distance from people, electric watercrafts and other objects.
- Do not ride immediately in front of, behind, or in close proximity to other electric watercrafts.
- Do not ride in areas where there are many other electric watercrafts in use.

# 1 Important labels

## 1.1 Warning label specification

- Avoid shallow waters or areas with submerged objects close to the surface.
- Take early action to avoid collision; remember that the eFoil do not have brakes.
- Never cross the path in front of a boat or other electric watercrafts, you may be hit resulting in injury or death. You should always take responsibility for watching marine traffic; other boaters may not be watching for you. There is a risk of collision, possibly resulting in injury or death, if other boaters do not see you or you move more quickly than they expect.

Do not attempt to modify this eFoil or any of its components. Modification to your eFoil may reduce reliability and safety, and render the eFoil unsafe or illegal to use. This will also void the warranty.

Use of this product includes inherent risks of injury or death. By using this product, you accept these risks.

Avoid making sharp turns at high speeds as there is an increased risk of injury due to the forces applied to your body and/or the product.

Always keep fingers away from the propeller. Contact with the propeller can cause serious injury or death. Never handle the propeller when a Flex BP is connected to the eFoil. Do not place your hands or anything else near the intake grate.

The product can potentially attract predatory marine wildlife. Be aware of your environment and its risks.

Consult your doctor before using the eFoil.

Never use the eFoil under the influence of alcohol or drugs.

Never use the eFoil if you are expecting or suspect that you could be pregnant.

Never use the eFoil after head or spinal injuries, or in poor health.

If you ride with two or more electric watercrafts, make sure to keep a safe distance in order to avoid collision; this may result in injury or death.

Do not use the eFoil or connect the Flex BP to a Flex Charger if any other than the usual lights on the Flex BP are active (See manual for LED overview).

If there are any red lights active for over 3 seconds, do not use the eFoil or charge

the Flex BP – open the app and navigate to the Support tab. Fill in your Contact Details,

Equipment Specifications and a Description of your issue. An Awake Product specialist will be in touch within 24h.

Never attempt to remove the Flex BP from the board or service the product in any way in water.

Never ride the eFoil without close-fitting protective clothing (i.e. wetsuit) for body cavity safety. Proper attire should be worn when operating the eFoil, casual swimwear does not provide adequate protection.

Never attempt to perform tricks or stunts, as you can put yourself and others at risk of injury or death.

Always head back to shore if the Flex BP has two (2) green dots left to make sure you get safely back to where you started.

Do not use the eFoil if there are any known or suspected problems with it.

Do not use your eFoil if the board or Flex BP has been damaged by being dropped or by collision. Contact support before use to determine if other actions are necessary.

Never expose yourself to the jet-thrust – this may result in injury or death. Do not engage the eFoil's Flex HC in shallow water, as debris can cause serious injury to the rider or others behind the jet. Do not push the Flex HC or accelerate the board when other people are in the water in front of or behind the board. Do not attempt to spray or splash water on others.

Avoid abruptly releasing the Flex HC at high speeds; sudden loss of speed can result in injury.

Always contact local boating authorities before riding the board in unfamiliar waters to get to know the local rules and also see the charts if there are any shallow places or objects in the water.

Follow all local rules and regulations for boating.

Avoid riding the eFoil in unfamiliar areas, as submerged objects and varying depths can threaten your safety.

# 1 Important labels

## 1.1 Warning label specification

Scan carefully for swimmers, and stay away from swimming areas. Swimmers are hard to see and you could accidentally hit someone in the water.

Make sure that the Flex BP and Flex HC are fully charged using only Awake Flex Chargers before each ride.

Always secure loose items such as long hair, jewellery, straps, and clothing before riding the eFoil.

**Do not touch or modify the eFoil/Flex BP connector or O-rings**

### 1.1.2 Awake Flex BP

**WARNING! HIGH VOLTAGE. DO NOT OPEN. TAMPERING WITH THIS Flex BP WILL VOID THE WARRANTY!**

Never attempt to operate on, disassemble, modify, or change this Flex BP in any way.

Use this Flex BP only for powering an approved product of Awake according to the manual.

Do not dispose of this lithium-ion battery. Such batteries must be handed over to specialized facilities for recycling or disposal.

Do not subject to impact, shock or physical damage.

Do not expose to fire or temperatures above 40°C / 104°F.

Do not expose to direct sunlight.

Do not charge this Flex BP in a wet area or an area with high moisture in the air.

Using this Flex BP in temperatures below 10°C / 50°F degrees may decrease the riding time.

Always let the Flex BP charge fully to avoid damage to the Flex BP.

Never try to open or repair the Flex BP, this should only be done by Awake or certified professionals.

Do not use the eFoil if there are any problems with it.

Do not use the eFoil or connect the Flex BP to a Flex Charger if any other than the usual lights on the Flex BP are active (See manual for LED overview).

Assemble all related product items in a dry environment.

Transport this Flex BP in accordance with all applicable laws.

Damage to this Flex BP may result in a fire.

Only charge with approved Awake charging equipment.

Do not handle this Flex BP and/or eFoil electronics with wet hands.

Inspect this Flex BP before every use or charge.

Do not use this Flex BP if you suspect it has been dropped or damaged in any way.

Do not connect this Flex BP or any electronics while in the water.

If any red lights are active for over 3 seconds, do not use the board or charge the BP.

For support: Connect to the Awake app and get in touch with support in the "Support" tab at the bottom of the screen. Enter your equipment details and send. An Awake product specialist will be in touch with you within 24h.

Always head back to shore if the Flex BP has two (2) green dots left to make sure you get safely back to where you started.

**FAILURE TO COMPLY WITH ABOVE STATED INFORMATION COULD RESULT IN ELECTRIC SHOCK, FIRE, SERIOUS INJURY, OR DEATH**



## 2 Safety information

### 2.1 General safety precautions

#### 2.1.1 Limitation on who may operate an Awake VINGA

- Awake recommends a minimum operator age of 16 years old.
- An adult shall always be present and supervise anyone younger than 18.
- A boating safety course is strongly encouraged before using the Awake VINGA.
- Never more than one person riding the VINGA at any time.

#### 2.1.2 Never use the Awake VINGA when:

- Under the influence of alcohol.
- Under the influence of any drugs, including prescription medication, which may impair your ability to operate machinery.
- Under the minimum age required by the local authority to operate a personal water craft (PWC).
- Using a pacemaker.
- Pregnant or suspect you may be pregnant.
- Physically or mentally impaired.
- Recovering from the head, neck, or spinal injury.
- Under 16 (sixteen) years, without an adult present and with adequate

knowledge of the VINGA and that also has read this manual first.

- Under the treatment of a disease and when you have been diagnosed with a physical or mental disorder.
- More than one person is on the board.
- When in a narrow canal, pool or in a pond.
- If owner is not covered by health insurance.
- If rider/owner is unfamiliar with navigational rules and regulations.
- In swimming areas or anywhere there is insufficient space for manoeuvring.
- In near proximity of other people located in or near the water.
- If not equipped with a coast guard approved Life Vest.
- Without wearing a full-face helmet.



Even when others operate the Awake VINGA the owner is generally responsible for damages or injuries that may occur. The owner of Awake VINGA must not allow any third party to operate the Awake VINGA without first informing of the correct use according to this manual and risks involved in operating the Awake VINGA.



## 2 Safety information

### 2.1 General safety precautions

#### 2.1.3 Equipment and Clothing

Always wear a Personal Flotation Device approved for use with personal electric watercraft by your local maritime authority when operating the Awake VINGA.

**A personal flotation device (PFD;** also referred to as a life jacket, life preserver, life belt, Mae West, life vest, life saver, cork jacket, **buoyancy aid** or **flotation suit**) is a piece of equipment designed to assist a wearer to keep afloat in water. The wearer may be either conscious or unconscious.

Awake recommends the use of at least class II PFD, which will self-right the rider if unconscious, clearing the airway and thus mitigating the risk of drowning.



It is critical that the PFD fits the user properly.

If you plan on sharing your Awake VINGA with your family and friends or rent to customers, it is the responsibility of the owner to ensure that any and all persons riding are equipped with an appropriate and suitable PFD's and fully informed of proper usage and risk involved. PFD requirements may vary depending on your location.

Always **wear a helmet** when operating the Awake VINGA. Always use helmets according to the manufacturer's instructions. Awake recommends the

use of a full-face helmet, which offers additional protection to the user's face. The use of a helmet may introduce additional safety hazards in some circumstances. "Bucketing" can occur during a fall as water can be caught in the helmet creating the drag, which may result in a severe neck injury, choking and death. The use of a helmet may also limit peripheral vision, resulting in reduced situational awareness. The rider should be aware of both the benefits and risks involved with using a helmet and make his or her own assessment.



Wear close-fitting clothing. Any straps or protrusions from the body must be secured, including hair longer than shoulder length. Long hair may be secured by a bathing cap or a hairnet worn underneath the helmet. A hair knot or similar securing method is not adequate as it may come undone. Articles such as items attached to your body may become entangled in the driveline resulting in serious injury, drowning, and death.

Wear protective clothing such as a wetsuit. Water may be forced into body cavities during a high-speed fall or when in close proximity to the jet nozzle, resulting in serious internal injury. High-speed impact with water may also cause injury.

The use of a wetsuit is recommended when riding the Awake VINGA. The type



## 2 Safety information

### 2.1 General safety precautions

and thickness of the wetsuit should be determined by water temperature conditions in your location. A wetsuit will help regulate body temperature in colder conditions and will also offer the rider some protection from cuts, scrapes, and friction burns when riding the board. Footwear, gloves, and goggles are also recommended.

The PKL should always be securely attached to the rider, preferably to the life vest, at all times when operating the Vinga (see “attaching the PKL” section for more detail). In case of falling off the board the engine will turn off. Note! Speed and weight will cause the board to continue moving, up 30 meters after a power stop when riding.

Be aware that there is a possibility of getting entangled in the PKL.



#### 2.1.4 Riding Safely Underway

Always keep in mind that when no power is being applied via the Flex HC, less directional control is available. To turn the board, both steering and some speed is necessary. Do not release the Flex HC when trying to steer away from objects. You need Flex HC and some speed to steer.

Never ride without the proper use of the PKL and magnet. When the Awake VINGA is in use the leash must be fitted securely to the operator at all times. The

PKL serves to cut all power and bring the craft to a halt should the operator fall off and should be safely and securely attached to the user's clothing or life vest before placing the PKL on the board. If the rider is separated from the board while moving at speed, the craft may continue to move forward for up to 30 meters.

Exercise extreme caution when riding, there is no way of controlling the eFoil once separated from the rider. Failure to operate the craft with a safe margin may result in injury, death and/or material damage to property.

While your eFoil has the capacity of operating at high speeds, it's only recommended to do so when conditions are ideal and without exceeding the permitted limit. High speed operation requires a higher skill level and poses an increased risk of severe injuries.

Only ride in sheltered waters. Never ride in strong currents, heavy swell or other conditions that may be beyond your abilities. Never ride in shallow areas or where the underwater terrain is unknown.

The use of this personal eFoil may attract predatory wildlife. Be aware of your environment.

Always be aware of the Flex BP and Flex HCs' charge level. Ensure you have enough charge remaining to bring you



## 2 Safety information

### 2.1 General safety precautions

safely back to shore.

Riders are not afforded any special rights while operating the Awake VINGA. All riders are responsible for complying with any and all local legislation concerning the use of the craft: maritime law, wildlife protection acts and more. The relevant local regulations vary depending on the user's location.

#### **2.1.5 Always ride with precaution and never:**

- Never ride without the attention of other people. Always make sure that aid is available in case of an emergency
- Never ride at night or in low visibility conditions. These conditions increase the risk of collision with other vessels, objects or terrain.
- Never attempt to be dragged or tow another person directly behind the jet. Items and debris could be accelerated at high speeds from the jet, potentially causing severe injury or death.
- Never ride the board over planning speed (over 10 km/h) when riding closer than 50 meters from the shoreline
- Never ride the board at planning speed (over 10 km/h) when being closer than 50 meters from swimmers, divers or other people

located in or near the water.

- Never ride the boards close to commercial ferries routes or waterways/sea-ways where other boats are traveling.
- Never ride your board in areas where there are boats traveling in close proximity.
- Never ride the board closer than 100 meters away from a traveling boat.



## 2 Safety information

### 2.2 Specific Safety Precautions

#### 2.2.1 Board & Driveline Safety

- Never place body parts or objects in close vicinity to the driveline while the Flex BP is connected to the board. Never attempt to service the product in the water; only in a dry environment.
- Never connect or remove the Flex BP when the board is in the water or when there is water within 3 meter or there is water or moist on the board power-connector or Flex BP connector.
- Avoid any and all debris in the water when in operation such as seaweed or rocks. Objects are likely to be sucked into the jet and may cause damage to the system or be ejected at high speed from the rear of the jet, potentially causing damage to property or injuries.
- Never remove the front cover when the Flex BP is connected to the board. The cover protects high voltage electrical components, which if damaged or tampered with may present a risk of electric shock and fire.
- Never attempt to dislodge debris from the jet when the PKL is attached to the Flex BP.



## 2 Safety information

### 2.3 Flex BP, Flex Charger, PKL

At all times charge with an approved charger supplied by Awake



#### 2.3.1 Handling of the

##### Flex BP

- Never attempt to open the outer Flex BP enclosure.
- Tampering with the Flex BP will void all warranties.
- Do not drop or induce shock of any kind to the Flex BP.
- Never remove Flex BP from the board while in use or in the water.
- Never connect or disconnect the Flex BP from the board with the PKL still connected
- Never connect or disconnect the Flex BP from the charger with the PKL still connected
- Never submerge in the water while detached from the board.
- Never loosen or remove the ventilation plugs on the exterior of the board, doing so may allow water ingress into the Flex BP and result in damage possibly resulting in injury.
- Never short circuit the Flex BP. Always take precautions to ensure that the conductive cable plugs do not come into contact with each other. This may happen through other bodies of conductive material, such as water or metals. A short circuit may cause irreparable damage to the Awake VINGAs' electrical systems.
- Never submerge the Flex BP when it is disconnected from the board, as this may short circuit the cable plugs. Never short circuit the plugs with your hands or any other body parts, as this may cause serious damage and injury to both the user and the Awake VINGA.
- Never open the Flex BP housing. Protect the Flex BP against mechanical damages.
- Use this Flex BP only for powering an approved product of Awake according to the manual. Do not dispose of this lithium-ion battery. Such batteries must be handed over to specialized facilities for recycling or disposal.
- Do not subject to impact, shock or physical damage.
- Always charge the Flex BP under the supervision of an adult and on a fire-resistant surface.
- Always charge and store the Flex BP in a cool area (under 30°C / 86°F)
- Always make sure the Flex BP



## 2 Safety information

### 2.3 Flex BP, Flex Charger, PKL

is placed on a flat surface while charging so that the bottom of the Flex BP will be able to transfer heat.

#### 2.3.2 Storage of the Flex BP

- Do not store the Flex BP in direct sunlight.
- Keep the Flex BP away from fire or glow, the Flex BP may explode if disposed of in fire.
- Keep at least 50 cm away from pacemakers
- Keep at least 50 cm away from magnetic cards (e.g. credit cards) and other
- Sensitive magnetic information media
- Do not expose to fire or temperatures above 56°C / 133°F.
- Do not leave this Flex BP unattended while charging. In case of inadvertent contact with the electrolyte discharged from the Flex BP (e.g. contact with the skin or eyes). immediately rinse the affected areas with copious amounts of water. Seek medical attention immediately.

#### 2.3.3 In case of incidents – Flex BP

In case of damage to the Flex BP housing: Stop using the Flex BP and stop charging the BP. Fire hazard!

- In case of electrolyte leakage from the damaged Flex BP: avoid contact

with the skin and direct inhalation of the gases.

- Never short-circuit the Flex BP.
- Charge the Flex BP only at ambient temperatures between 0°C and 45°F.
- If there are any continuous red lights or any lights other than the usual lights on the Flex BP display – **DO NOT CHARGE** or use the BP in the board. Place it as soon as possible in a cool and fire-safe area as it may have internal damage and therefore be dangerous and risk starting a fire or smoke. Call +4687777270 and send an e-mail to [support@awakeboards.com](mailto:support@awakeboards.com) directly for service support.
- If the Flex BP has been dropped or there is any visible damage to the Flex BP – **DO NOT CHARGE** or use the Flex BP in the board. Place it as soon as possible in a cool and fire-safe area as it may have internal damage and therefore be dangerous and risk starting a fire or smoke. Call +4687777270 and send an e-mail to [support@awakeboards.com](mailto:support@awakeboards.com) directly for service support.
- Always charge and store the Flex BP in a cool area (under 30°C / 86°F)
- Always make sure the Flex BP is placed on a flat surface while charging so that the bottom of the Flex BP will be able to transfer heat



## 2 Safety information

### 2.3 Flex BP, Flex Charger, PKL

away from the Flex BP.

- Always make sure you have at least one ABC or BC Dry chemical fire extinguisher between 5 and 15 meters away from the Flex BP any time you store it or charge it to be able to put out any smoke or fire.
- Never store or charge the batteries in an area with flammable liquids or other flammable material nearby.
- In the unlikely event that your lithium Flex BP catches fire try to position it such that it causes the least possible damage.
- Water cannot extinguish a lithium fire – if possible, extinguish the fire with sand.
- Never obstruct airflow to the ventilation cover when in use.
- Never use if cables and/or connectors are damaged.
- Never use it when connectors are wet or dirty.
- Allow time to cool off after charging before handling or storage as the charger heats up.

#### 2.3.5 PKL

#### 2.3.4 Flex Charger Safety



Never use the Awake Flex Charger for any other purposes than to charge an Awake Flex BP.

- Never open the Flex Charger.
- Never drop or submit the Flex Charger to other shocks.
- Never short circuit the Flex Charger.
- Never store or use the Flex Charger in sunlight or other hot environments.
- Never attempt any maintenance or repair by yourself.
- The PKL / CPK may affect the operation of pacemakers, therefore keep the PKL / CPK away from pacemakers (at least 50 cm /20 in).
- The PKL / CPK may affect electronic and magnetic instruments (e.g. compass).
- Keep the Flex HC and the PKL / CPK apart (don't store/keep in close proximity of each other. The Flex HC has magnetic components that can be compromised by the PKL / CPK).
- Be careful with the leash, as it could get entangled to your body or around your neck, potentially strangling you or someone else, resulting in injury or death.



## 2 Safety information

### 2.3 BP, Charger, PKL



#### 2.3.6 Environment and disposal of Flex BPs, Flex Chargers, PKL etc.

- Contact Awake or one of Awake's Service Center for instructions on how to dispose of the damaged Flex BP.
- The Flex BP must not be disposed of by incineration, land filling, or mixing with household waste. Improper disposal of the Flex BP may result in the Flex BP heating up, rupturing or igniting which may cause serious personal injury, and will directly result in harming the environment.
- The substances contained inside the Flex BP present chemical risks to the environment. The recommended disposal for any VINGA at its end-of-life is to dispose of the entire unit at or through an e-waste recycling center, program, or facility.
- Local regulations and laws pertaining to the recycling and disposal of lithium ion batteries and/or products containing them will vary according to country, state, and local governments. You must check laws and regulations corresponding to where you live in order to dispose of the Flex BP properly. It is the user's responsibility to dispose of their waste equipment properly in accordance with local regulations

and laws.

- For additional information about where to drop off your Flex BPs and electrical or electronic waste, please contact your local waste management office or household waste disposal service.



## 2 Safety information

### 2.4 Critical user procedures



Make sure all connection points are **COMPLETELY DRY** before inserting/  
connecting the Flex BP



Never insert/connect or disconnect the Flex BP when the board is in the water



Never insert/connect or disconnect the Flex BP to the board when the PKL is  
connected to the Flex BP



Never insert/connect or disconnect the Flex BP to the charger when the PKL is  
connected to the Flex BP



To avoid unbalanced cells inside the Flex BP, always charge the Flex BP to 100%  
charge (all green static lights on the LED display)

## 3 Operation

### 3.1 Before using the eFoil

#### 3.1.1. Download the Awake app:

Apple/iOS



Android



#### 3.1.2 Connecting to the Flex BP via Wireless connection

In order change rider profiles and monitor important data from your RÄVIK, you will need to connect your mobile device to the Flex BP via Wireless connection technology.

Turn on Wireless connection on your mobile device and open the Awake App. Upon opening on the home tab, the app will automatically begin searching for the Flex BP.

If your Flex BP was not discovered after the first auto search, swipe down to refresh. Once discovered, your Flex BP(s) tap the desired Flex BP to connect. Once successfully connected, the  icon will light up in blue.

The first time the battery is used, it will have to be activated via the App. The activation process includes registering the product into the Gear garage in your user Awake rider account. Either login to an existing account or register a new Awake rider account in the Awake app.

#### 3.1.2 Activate the battery

The battery is activated by opening and closing the rotating handle.



#### 3.1.3 Binding Installation

Before installing the bindings, you will need to know your preferred stance – regular (left foot forward) or goofy (right foot forward). This will be whatever feels more natural to you. If you are unsure, have someone gently push you from behind, with your arms initially held alongside your torso, and whichever foot goes forward will usually be your front foot.

To install the bindings, position each binding according to your preferred angle and spacing, ensuring the fastening holes are located above the inserts along the center of the board.

Fasten the bindings to the board using the provided M6 x 15 screws and Allen Key. Make sure the bindings are tightly secured to the board before riding.

#### 3.1.4 Wings Installation

Position the Drive Unit upside down. Ensure stability by using the strap

# 3 Operation

## 3.2 Getting started

Install the wings with provided screws, shims and tool. Make sure all screws are engage to the thread before fully tightening.

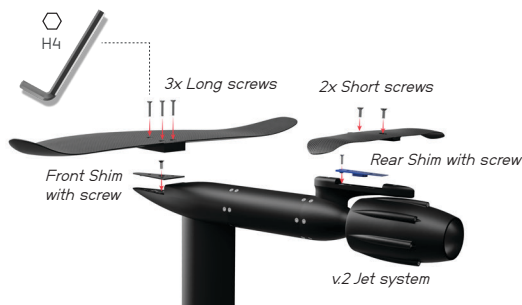

When receiving your wings set, you will find shims / spacers for both front and rear wings. The black front shim is the same for all wings. The rear shim is blue for Powder wings and red for Cruise and Fluid wings.

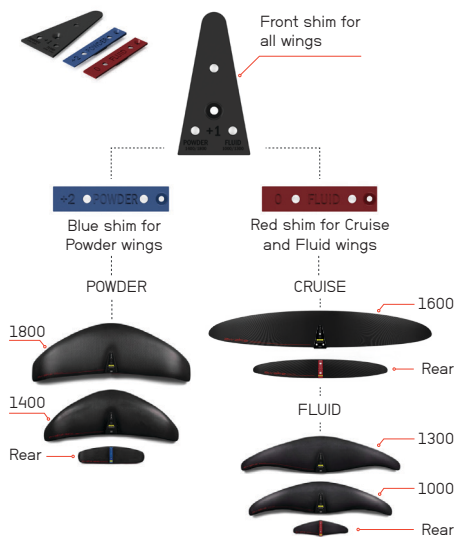

### 3.1.5 Click-to-Ride

The VINGA has a Click-to-Ride system that allows the board to be connected to the Drive Unit in a few easy steps.



1. Put the drive unit standing straight on the ground, with the CM facing up.
2. Grab the board and carefully slide it onto the CM on the drive unit.
3. Fasten the connection with both the larger main lock (black) and the smaller safety lock (red).
4. Make sure that the connection is solid by lifting the board and the wing. Grab the board by the front handle of the board and the cut-out in the back. 3.2.1 Insert and Remove the Flex BP

The Awake VINGA features a Flex BP, which must be removed for charging. The design also allows for fast swapping while on the go if you own multiple Flex BPs.

To install the Flex BP into the board, first, check that there are no foreign objects or

## 3 Operation

### 3.2 Getting started

dirt/sand in both the Flex BP and board connectors. Ensure the board is laying securely on an even surface and lift the Flex BP using both handles.

Slide the front end of the Flex BP into the designated cavity in the board, resting the Flex BP's retention notches underneath the retention tabs.

The locking handle should be perpendicular to the deck, locating the slots onto the locking pins on the board. Push the locking handle down towards the board until the Flex BP is firmly secured, there should be an audible "click".

Always check that the Flex BP is installed securely by pulling on the handle before riding.



#### 3.2.2 Attaching the PKL

The Awake VINGA should only ever be used with the PKL securely fitted to the operator at all times. Care must be taken to ensure that the leash is secured to the body in a fashion in which it cannot be easily detached, the leash must not be attached to swimwear which can fall from the user. The PKL must be safely secured to the rider before attaching the PKL to the board.

#### 3.2.4 Activating the eFoil

Activate the battery by inserting it into the board.. The LEDs on the Flex BP will

illuminate Green, indicating the charge level of the Flex BP. A notification sound will trigger from the Flex BP, confirming that the Flex BP is activated and ready for operation.

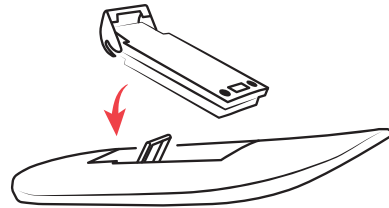

## 3 Operation

### 3.5 Riding the VINGA

1. Start by lying down on the board and face riding direction. Push the throttle on the HC to go forward.

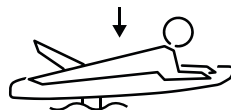

2. Once a comfortable planning speed is reached, get up on your knees.

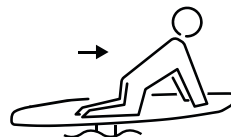

3. Put your front foot forward on the board (left foot for REGULAR and right foot for GOOFY)



4. When planning, lean back to take flight and compensate with weight forward. In flight, balance the board by moving back and forth.

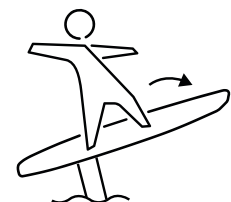

5. To break, release the throttle, and to turn, lean your body forwards and backwards and look over the shoulder in the direction you want to turn.

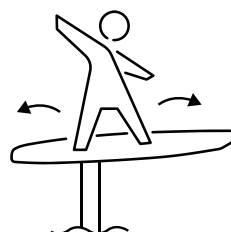

# 3 Operation

## 3 Operation

### 3.3 Using the Flex HC

#### 3.3.1 Power on / off the HC

Power on the HC by pressing any button on the HC. The Awake logo is displayed and a vibration is felt in the handle.

Power off the HC by navigating either to the Power button  in the top left corner of the display, or press and hold the Select button for 1 second.

#### 3.3.2 General settings

Change Ride settings, interface settings or see HC diagnostics through the General Settings menu -> 

#### 3.3.3 Ride settings – Power Levels

Your VINGA can be set to 10 different Power Levels where 1 provides lowest speed and 10 maximum speed. The Power Level setting is adjusted and stored in the Hand Controller, even when switching battery or board.

#### 3.3.4 Ride settings – Throttle safety

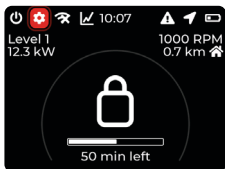

#### PKL lock

The board activates and charges without PKL installed, but need a PKL installed for riding.

#### Smart lock – recommended

The HC throttle will be locked if idle for more than 10 seconds. If the HC is submerged, the HC will be locked if idle for 3 seconds.

#### No Safety

The board will activate and ride without PKL installed, and will not lock when submerged or left idle.

#### 3.3.5 Interface settings

Set screen brightness, choose between Default or Basic riding screen, change units and adjust time zone.

#### 3.3.6 Diagnostics

See the current status of your HC in the Diagnostics section of the General Settings menu. See throttle value, current HC temperature and firmware versions.

#### 3.3.4 Ride screens

Go to General Settings  and to Interface Settings to change between ride screens.



Default

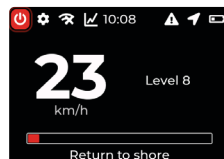

Basic

# 3 Operation

## 3.3 Flex HC / BP Features and Displays

### 3.3.1 Disconnect HC from BP

Use the buttons to navigate to the  icon and press select to disconnect the HC from the BP.

### 3.3.3 Ride statistics

Use the buttons to navigate to the  icon to see your ride statistics such as:

- > Ride minimap
- > Session time
- > Ride distance
- > Top speed
- > Average speed
- > Peak power

### 3.3.7 HC display overview

Use the buttons (left/select/right) to navigate between the HC functions.



- ⏻ On / Off
- ⚙️ General Settings
- 🔌 Disconnect HC
- 📊 Ride Statistics
- 📍 Navigation services
- 🔋 State of charge

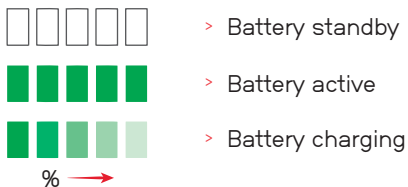

### 3.3.1 BP Display overview

Go to General Settings  and to Interface Settings to change between ride screens.



-  > HC and/or app disconnected
-  > HC and/or app connected
-  > Wireless connectivity faulty

> Notification  
*(see HC display)*



> Warning  
*(see HC display)*



> Error  
*(see HC display)*



## 3 Operation

### 3.4 Charging

#### 3.4.1 Charging the Flex BP

Charge the Flex BP within 24 hours of each cycle of use. During longer periods of storage (for example during off-season) make sure to maintain a state of charge at 80% in order to avoid irreparable total discharge of the Flex BP.

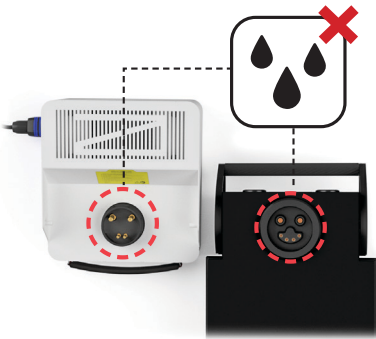

Before charging the Flex BP, place the charger on a clean level surface with enough clearance for the Flex BP once connected. Ensure that there are no foreign objects in both the charger connector and Flex BP connector and dry with a towel to remove any moisture.

1. Connect the provided C14 power cable connector to the charger. Connect to a suitable wall outlet.

2. Place the Flex BP on the charger and align the front locking slots with the locking pins.

3. Push the locking handle down and towards the charger until the locking slots fully engage the pins. The locking handle should be parallel to the top of the Flex BP.

4. BP LEDs turn green in sequence from left to right. The charging progress is communicated via the charge LEDs where each LED represents 20% charge.

A full charge of the Flex BP takes approximately 80 minutes. When charging is complete, all 5 charge LEDs turn solid green and the charger fan will switch off.

If overheating of the Flex BP occurs at any time during the charging process, the battery will automatically activate a low power mode and adjust the charging speed accordingly.

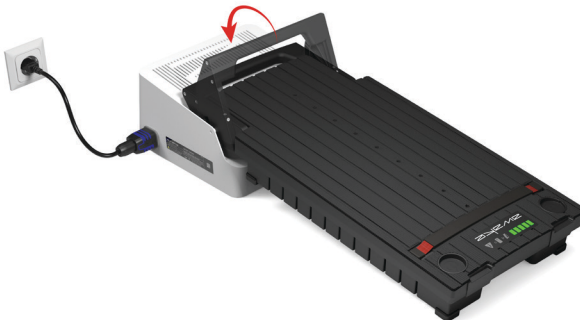

## 3 Operation

### 3.4 Charging

#### 3.4.2 Charging the HC

To charge the Flex HC, first, connect the USB A wireless charger connector to the provided DC power supply and plug it into a wall outlet.



Alternatively, the wireless charger can be connected directly to any USB outlet intended for charging (for example in a car or personal computer)

Place the Flex HC into the wireless charger slot.

A dynamic charging sequence image on the display will indicate that the Flex HC is in a charging state. Once fully charged, the dynamic charging sequence image will turn static and a dialogue will confirm that the Flex HC is fully charged,



The state of charge can be found at any time in the top right corner of the display when the Flex HC is activated.

*HC state of charge*

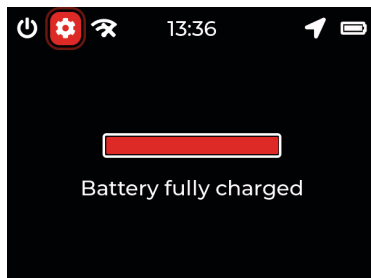
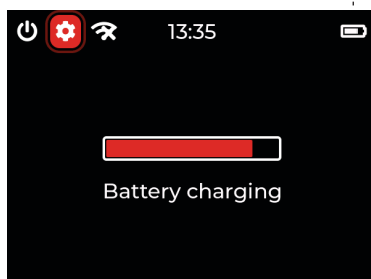

# 4 Transport and Storage

## 4.1 Transport

### 4.1.1 Vehicle Transport

For longer journeys, it's best to transport the Awake VINGA in a car or other personal vehicle.

Depending on your location, public transport authorities may not allow oversized luggage and using public transport has an added risk of damaging the board and/or its accessories.

When transporting the board and its accessories in a personal vehicle, always secure the board bag with straps so that they do not move during transit.

The board bag may also be transported on a roof rack or in a roof equipment box. In these cases, it is imperative to use your protective bag and adequate securing equipment.

During transport special care should be given to the Flex BP. Always make sure that it is securely strapped down.



If the Flex BP is in any way dropped or scratched – do not use or charge the Flex BP – contact Awake for an assessment of it before doing anything with it.

In the event of a vehicle accident, the Battery cells within the Flex BP may be ruptured, causing the release of flames and toxic gases. Any suspicion that the Flex BP has been ruptured in an accident should immediately be reported

to emergency services attending the scene.

In case of fire, cover the Flex BP with a fire blanket or use a fire extinguisher recommended for lithium ion battery fires.



**NEVER ATTEMPT TO EXTINGUISH A BATTERY FIRE WITH WATER!**

### 4.1.2 Air Transport

The Flex BP uses lithium-ion battery cells. They are therefore considered as hazardous goods and are only eligible for air freight in accordance with the UN 38.3-certification.

Customers, resellers, distributors or any other party are therefore prohibited by international law from transporting, shipping or sending the Flex BPs via any form of air transport/freight/shipping.

For information regarding utilizing Awake VINGA at various locations, please contact Awake in advance.

## 4 Transport and Storage

### 4.2 Storage

#### 4.2.1 Board Bag

The VINGA Board Bag Kit consist of two connectable bags: A bag for the Board and a bag for the Drive Unit.

The Awake VINGA Board Bag is provided with removable wheels. Due to the weight of the board and all its accessories, we recommended using the wheels even for transporting the board short distances. To install the wheels, first, slide the axle through the opening located outside the bottom of the bag.

Attach the wheels on either end of the axel by depressing the quick-release button in the center of the wheel, sliding the wheel shaft into the axle and then releasing the quick-release button.

Never drag the Awake VINGA along the ground or other surfaces. Doing so may cause wear to the body in such a way that it's water protective capacity is compromised. This may also sharpen the fins to a point where they become a cutting edge and pose a risk to personal safety.

#### 4.2.2 Board Storage

Never store the Awake VINGA in water. Storing the Awake VINGA in the water may result in biological growth on and around the impeller and the jet housing, causing power loss. Should you have to leave the Awake VINGA in water for a short time, always make sure that it is moored in a secure manner.

**Never leave the Awake Vinga unattended to prevent children or other inexperienced persons from using it.**

#### 4.2.3 Flex BP Storage

When storing the VINGA for long periods of time, it's recommended to remove the Flex BP and store it separately.

The Flex BP must be charged between 80% of maximum capacity when in storage (4 bars on the LED display). Always be sure to store your Flex BP in a safe and dry environment that is not subject to large fluctuations in temperature. Check the charge level periodically (approx. once a month) during storage to ensure the charge remains within the required range. See section 4.3 for more information.

#### 4.2.4 Flex HC Storage

The Flex HC should be rinsed with fresh water after every use. It must be charged to 80% of its maximum capacity when stored for long periods of time.

Check the charge level periodically (approximately once a month) during storage to ensure the charge remains within the required range.

## 4 Transport and Storage

### 4.3 Winterization (long-term storage)

If you are planning not to use the board for an extended period of time (one month +), it's crucial that the Flex BP is kept at a **nominal charge level of 80%** throughout the storage period. This is because the Battery cells will otherwise deplete, rendering the Flex BP unusable, and in need of getting shipped back to Awake for repair (an action that is not covered by any warranty or guarantee).

Make sure to adhere to the following steps for winterization:

1. Rinse of all parts of the board and Flex BP with fresh water, and make sure to let everything dry properly
2. Spray the CMs on both the board and the Flex BP with contactor spray
3. Charge the Flex BP up to at least 80% (four bars on the LED display)
4. Disconnect the PKL (you can leave the Flex BP on the charger if convenient)
5. Check the status of the Flex BP and put it on charge for 10 min at least every two months by simply connecting the PKL and connecting it to the app.
6. If you have the winterization function in the app, simply follow the instructions for correct action in keeping your Flex BP at an optimal state of charge.
7. If you do not see the winterization function in the app and you notice that the charge level has dropped to three bars on the LED display, let the BP charge for 15–20 minutes, or until the charge level has gone up to four bars on the LED display.

# 5 Maintenance

## 5.1 Maintaining the Awake VINGA



**Never attempt to repair or open the Awake VINGA by yourself. Any procedures not covered or described in this section are only to be carried out by an authorized technician at your nearest dealership or by Awake.**

### 5.1.1 Post-Ride Care Routine

Depending on where you ride, the water may contain lime, salt and other minerals. Residues from these minerals may be deposited on your Board and Drive Unit as the water dries. Large deposits on the hull will impact your maximum speed, and deposits on the impeller and other drive unit components may cause corrosion. It is therefore recommended that you always rinse the entire board and Drive Unit with fresh water and a dry with a cloth after each use cycle. Care should be taken to ensure that all areas of the board are rinsed, including small cavities.

*Note! Do not use high pressure water or air when rinsing or cleaning the equipment.*

The Flex HC should also be rinsed with freshwater and dried before storage.

Depending on your location, air moisture levels may be high. For this reason, you should regularly keep the electrical connectors clean. The connector plugs are cleaned by carefully wiping them with a dry cloth.

### 5.1.2 Hull Maintenance

In order to maintain a high-quality surface finish on the VINGA, a wax suitable for marine applications should be applied to the hull of the board periodically.

Should the hull sustain any minor cosmetic scratches or cracks it may be repaired by the user. Carefully sand down the area surrounding the damage using fine-grit sandpaper, fill any cracks with marine grade epoxy, then re-apply a suitable clear lacquer.

In the event of serious damage to the hull, or you are unsure about the severity of damage to your hull, contact Awake.

### 5.1.3 Drive Unit Care

To preserve an efficient connection between the Flex BP and the Drive Unit, it is important to rinse off the gold pins on the connector module with fresh water after each ride. It is also recommended to treat the gold pins on the connector module with contactor spray at the end of every ride session, to further protect them from corrosion.

To keep the precision fitting of your Wings, it is recommended to remove the Wings from the Drive Unit after every ride and clean out potential debris such as sand, salt or sea weed.

Check for loose parts on the jet system after every ride. Tighten if needed.

# 6 Troubleshooting and diagnostics

## 6.1 System notifications

Notifications from and about the entire board system are shown on the HC display with a dialog describing type of notification, reason and proposed action.

### 6.1 Battery notifications



The triangle on the BP LED display will shine white for information, yellow for warning and red for error. Below is a list of all possible battery related notifications:

#### 6.1.2 Battery info:

Charging speed reduced. -> Battery needs to cool down.

Performance reduced. -> Battery needs to cool down.

Battery needs to cool down

Apply PKL to activate throttle

Board is upside down. -> Throttle disabled for safety.

Lock the battery handle to enable the battery.

#### 6.1.3 Battery Warning:

Battery warning detected. -> Contact support.

Battery cells are unbalanced

Faulty sensors detected. Running in safe mode. -> Contact support.

Battery is low. -> Return to the shore!

Battery is empty. -> Charging needed.

This screen disables throttle. -> Return to ride screen to enable it.

#### 6.1.4 Battery Error:

Battery error detected. -> Contact support.

Battery temperature out of range

Short circuit detected in battery. Power is disabled -> Contact support.

Water detected on the battery connector -> Dry it out and try again.

Water detected inside the battery -> Contact support.

# 6 Troubleshooting and diagnostics

## 6.2 Board notifications

### 6.2.2 Board warning:

Motor is overheating. -> Performance is reduced.

Motor controller is overheating. -> Performance is reduced.

### 6.2.3 Board error:

Connector module motor controller fault

Unsupported board type. Throttle disabled. -> Contact support.

## 6.3 HC notifications

### 6.3.2 Hand controller info:

Throttle safety lock: Hold middle button for 3 seconds with throttle released to unlock.

### 6.3.3 Hand controller warning:

Hand controller battery is very low. -> Charging is needed.

Hand controller battery is getting low

Throttle disabled due to PKL presence. -> Move PKL away from the HC.

Hand controller is overheating. -> Move it to a cool place to cool down.

### 6.3.4 Hand controller error:

Wireless module is faulty. Connections are not possible.

Water inside the hand controller. Throttle disabled.

Data storage fault. Setting may not work.

Throttle sensor is faulty. Throttle disabled.

# 7 Warranty

## 7.2 LIMITED Warranty

The warranty only applies to products delivered by Awake and exists only towards the customers of Awake or it's contracted re-sellers. It does not apply to any third-party purchaser. The warranty covers any manufacturing defects or defects in materials from the invoicing date and where such products are used under normal operating and maintenance conditions for a period of 12 months for all products.

To invoke the provisions of the warranty, the customer must notify Awake, in writing and within the above-stated warranty period, of the defects allegedly found in the products and provide proof thereof. The customer must facilitate the assessment of these defects. The customer shall not, without the prior written consent of Awake, carry out any repair or removal him-/herself or arrange for doing so by a third party.

Under the terms of the warranty, Awake may, at its sole discretion, choose whether to supply new products (of the same type if still available), repair or replace the products, ex-works, all the products covered by the warranty and found to be defective by Awake. Awake shall not be liable to pay any compensation for any reason whatsoever and in particular for any loss or damage of any kind (physical, material or financial loss in relation to the [allegedly] defective products, loss of business, loss of revenue or loss of reputation, etc.)

Repairs or replacements made under the terms of warranty shall not extend the warranty period. Parts replaced during the warranty period shall be returned to Awake and shall become the property of Awake.

### 7.2.1 Limitation of liability

Awake excludes all liability for and the warranty shall not cover any defects (and any damage whatsoever arising there from) resulting from;

any assembly or installation or use of the products that do not comply with Awake's instructions or specifications (documentation, operating and assembly instructions, special recommendations, etc.) or professional standards,

abnormal use of the products, defective or unsuitable maintenance, negligence or any use other than the use for which the products were intended,

materials supplied (or design imposed) by the customer, or from service or maintenance performed on the products by third parties not expressly authorized by Awake,

acts of God or force majeure as well as defects and consequences thereof resulting from normal wear and tear of the Product,

Awake shall not be liable for any warranty other than listed above.

## 8 Technical Specifications

### 8.1 Awake VINGA eFoil

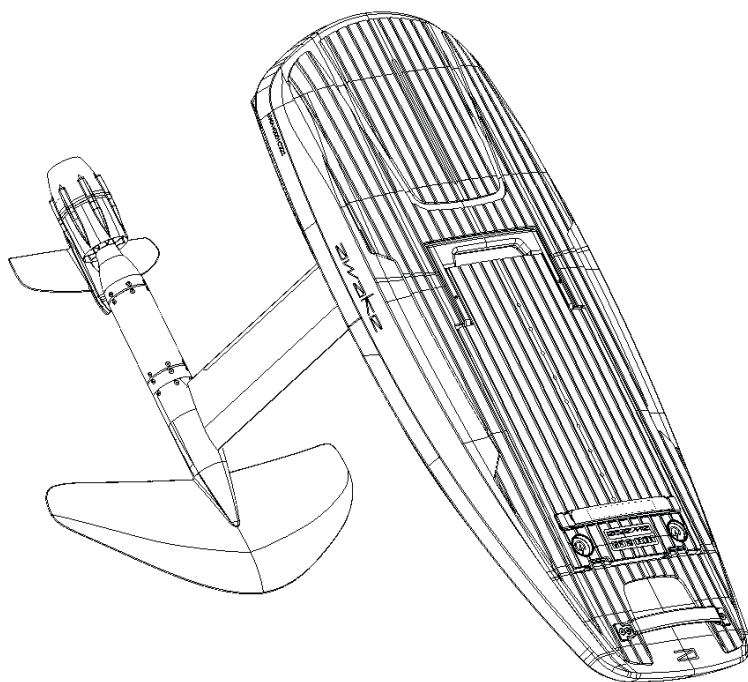

# 8 Technical Specifications

## 8.1 Awake VINGA Ultimate Board

**Hull:**

Carbon/Innegra  
composite foam core  
sandwich monocoque

**Passenger Capacity:**

One (1) operator

**Max Rider Weight:**

110 kg / 242 lbs

**Absolute Max Weight:**

136 kg / 300 lbs

**Volume:**

60 L

**Weight:**

7.8 kg / 15 lbs

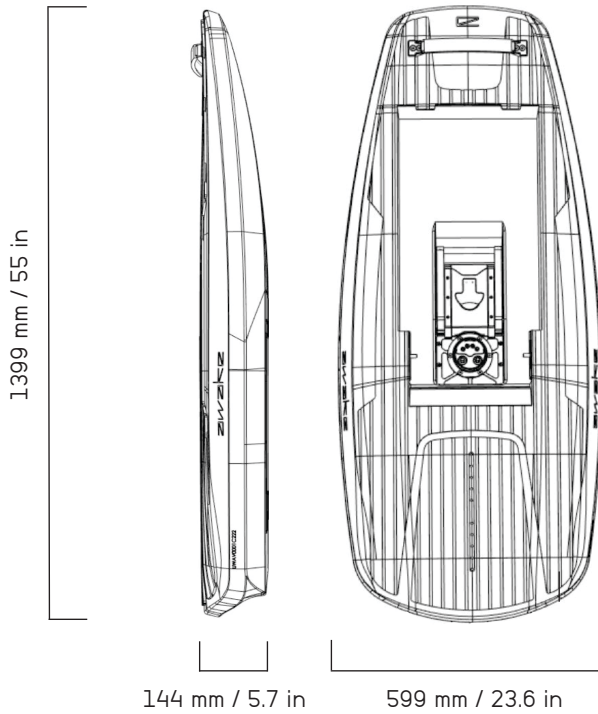

## 8 Technical Specifications

### 8.2 Awake VINGA Adventure Board

**Hull:**

Carbon/Innegra  
composite foam core  
sandwich monocoque

**Passenger Capacity:**

One (1) operator

**Max Rider Weight:**

110 kg / 242 lbs

**Absolute Max Weight:**

136 kg / 300 lbs

**Volume:**

95 L

**Weight:**

9.5 kg / 21 lbs

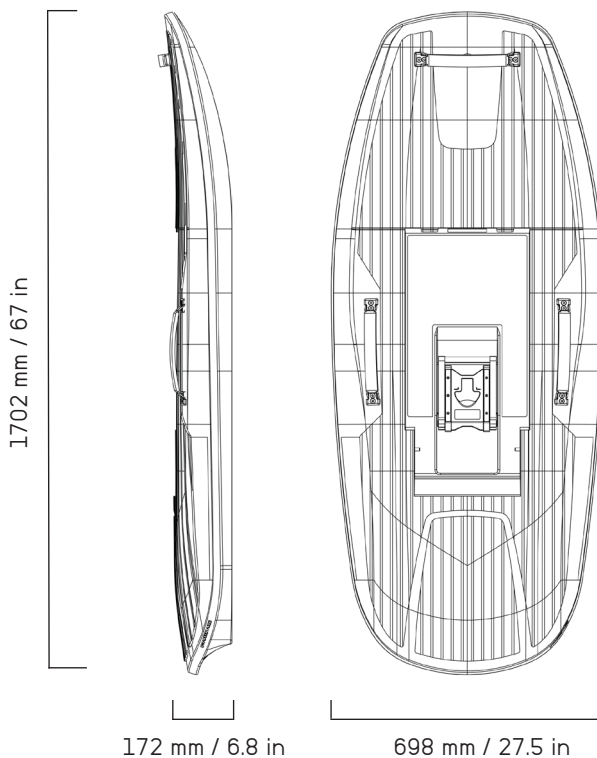

## 8 Technical Specifications

### 8.3 Awake VINGA Drive Unit

**Mast:**

Anodized Aluminium

**Motor:**

Awake-Motor 8.16 kW Brushless DC

**Connector Module:**

Awake-CM

**Cooling:**

Passive water cooling

**Weight:**

11 kg / 24 lbs

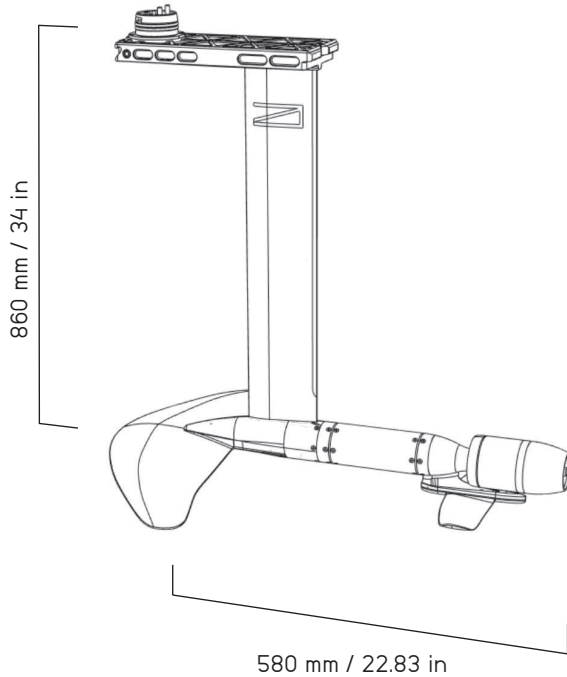

## 8 Technical Specifications

### 8.4 Awake VINGA POWDER Wings

**Material:**

Carbon Fiber

**Weights:**

**Wing 1800**

1.1kg / 2.4 lbs

**Wing 1400**

0.93 kg / 2.0 lbs

**Wing rear**

0.30 kg / 0.66 lbs

**Powder Wing 1800**

834 mm / 32.8 in

270 mm  
/ 10.6 in

70 mm  
/ 2.76 in

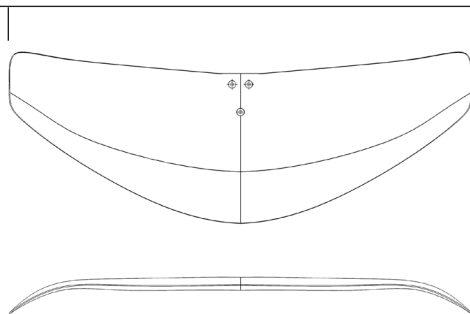

**Powder Wing 1400**

746 mm / 29.4 in

248 mm / 9.8 in

54 mm / 2.1 in

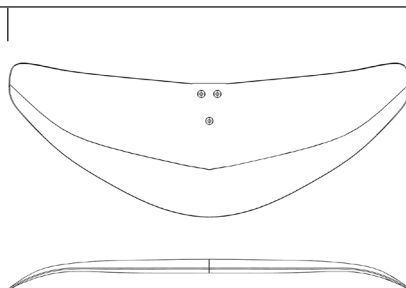

**Rear Wing**

356 mm / 14 in

92 mm / 3.6 in

26 mm / 1.02 in

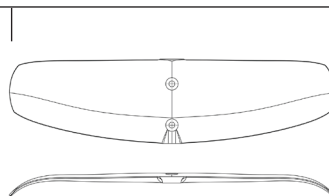

# 8 Technical Specifications

## 8.5 Awake VINGA FLUID Wings

### Material:

Carbon Fiber

### Weights:

#### Wing 1000

0.8 kg / 1.8 lbs

#### Wing 1300

0.95 kg / 2.1 lbs

#### Wing rear

0.12 kg / 0.26 lbs

### Fluid Wing 1300

933 mm / 36.7 in

217 mm  
/ 8.5 in

49 mm  
/ 1.9 in

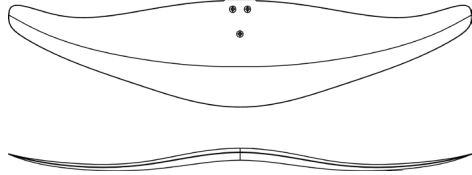

### Fluid Wing 1000

807 mm / 32 in

182 mm / 7.7 in

46 mm / 1.8 in

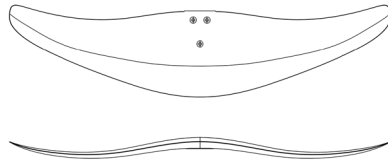

### Fluid Wing rear

325 mm / 12.8 in

92 mm / 3.6 in

14 mm / 0.55 in

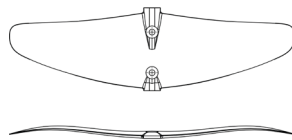

## 8 Technical Specifications

### 8.5 Awake VINGA CRUISE Wings

**Material:**

Carbon Fiber

**Weights:**

**Wing 1600**

1.4 kg / 3 lbs

**Wing rear**

0.35 kg / 0.77 lbs

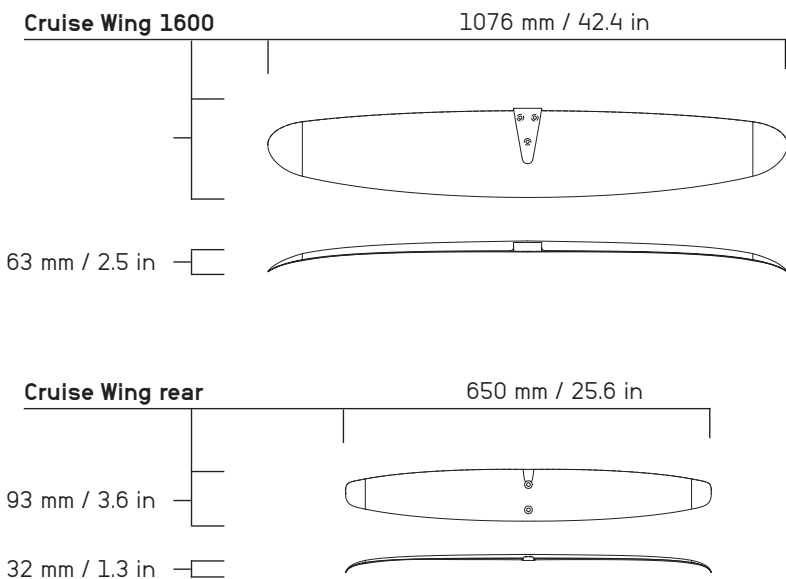

# 8 Technical Specifications

## 8.4 Awake Flex BP 4 LR

**Weight:**  
12.1 kg / 26,7 lbs

**Battery energy:**  
Li-Ion 1,3 kWh

**Nominal voltage:**  
86,4 V

**Dimensions:**

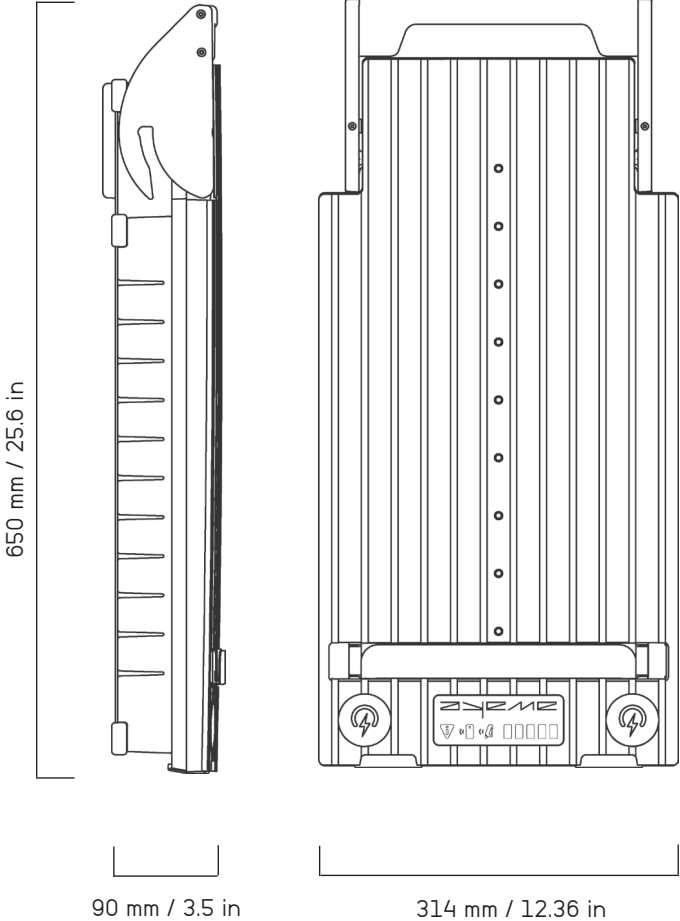

## 8 Technical Specifications

### 8.5 Awake Hand Controller 4

**Weight:**

255 g / 9 oz

**Dimensions:**

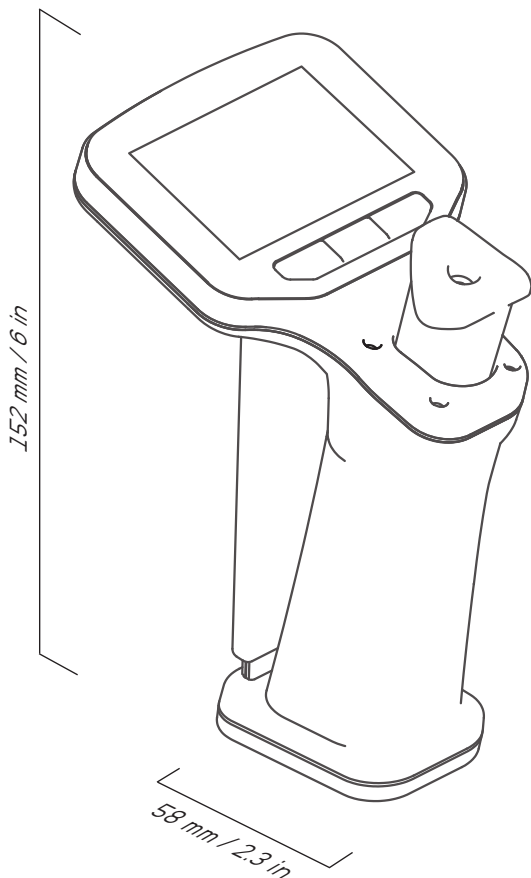

## 8 Technical Specifications

### 8.5 Awake Flex Battery Charger

**Weight:**

11 kg / 24 lbs

**AC Input:**

90-265VAC 50/60Hz 9A

**DC Output:**

89.1V 16A@220VAC

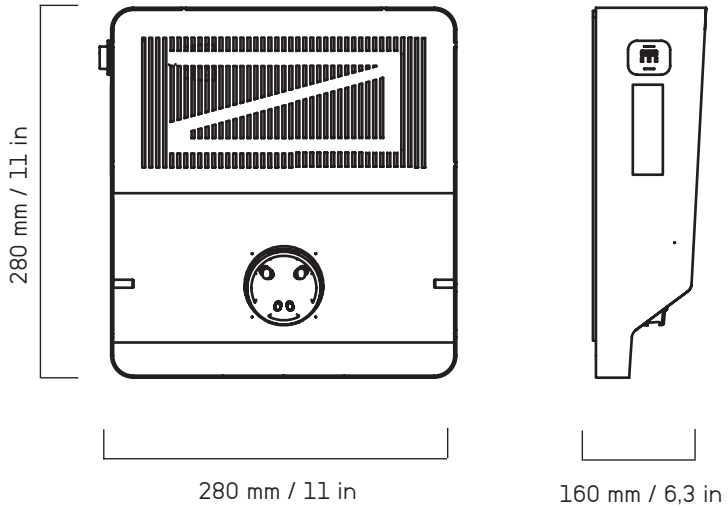



## 9 Contact Us

If you have any questions about this User Manual, its content, either in parts or in its entirety, please don't hesitate to reach out to [support@awakeboards.com](mailto:support@awakeboards.com), We are at your disposal.

Ride Awake AB

Frihamnsgatan 26  
115 56, Stockholm  
Sweden

[info@awakeboards.com](mailto:info@awakeboards.com)  
+46 (0) 877 77 270  
[awakeboards.com](http://awakeboards.com)

# Stay Awake



ELECTRIC SURFBOARDS AND FOILS



awake

[www.awakeboards.com](http://www.awakeboards.com)